

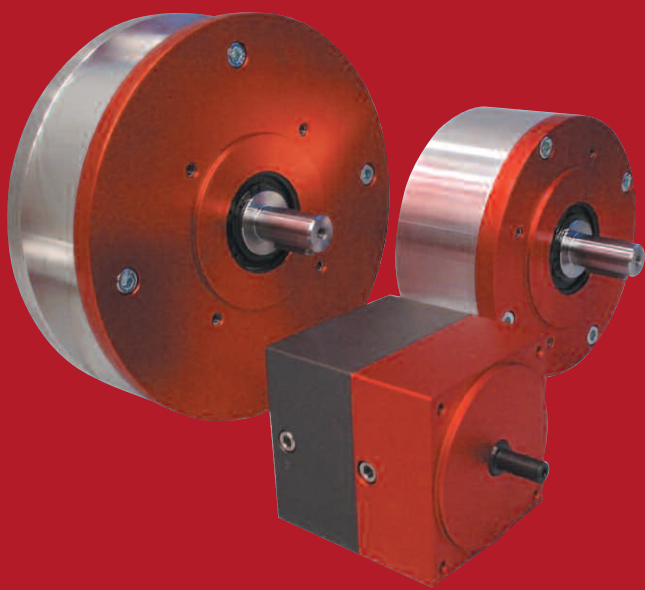

GLOBE

COMPACT PISTON AIR MOTORS



Your Global Force In Air Power



GLOBE AIR POWER

Compact Piston Air Motors

ATEX

Ex II-2-GDc-T5

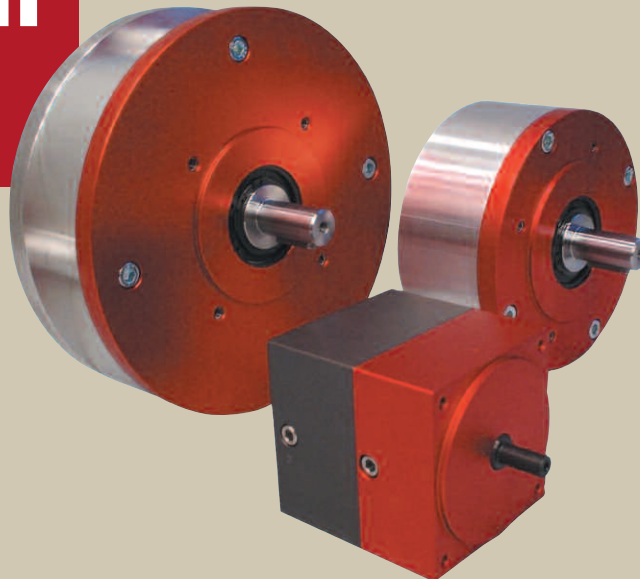

WORKING PRINCIPLE

The compact radial piston air motor operates without rod or crank shaft. The radial arranged pistons travel along a curve and are controlled by the centre.

The static control shaft supplies the driving pistons with the necessary air. Air supply and release openings along the static shaft are periodically opened and closed by the rotation of the rotor to pressurise or release the pistons in an appropriate sequence.

Three of the seven pistons are contributing to the torque at any moment, when being driven down one of the four curves. When reaching its lowest point on the curve, the pistons can release the air through the static shaft.

CONTENTS

	PAGE
ADVANTAGES/WHY CHOOSE A COMPACT PISTON AIR MOTOR?	3
APPLICATIONS/CONTROLLING AIR MOTORS	4/5
GEARED PISTON AIR MOTORS	5
RM004	6
RM015-1-A-0	7
RM015-1-P-0	8
RM025-1-A-0	9
SPECIAL EXECUTIONS	10
LOAD DIAGRAM	11
MODEL ORDERING CODE	11

Photos on the front cover on courtesy of:

BPL, Haelen (NL) – Manipulator

Duits Engineering, Zutphen (NL) – Turning device

Gritco Equipment BV, Ridderkerk (NL) – Sand blasting equipment

Aerofilm Systems BV, Eindhoven (NL) – Lifting table

EMCE, Voorhout (NL) – Winch

Hydrauvison, Schoondijke (NL) – Powerpack

ADVANTAGES

Air motors offer a unique form of drive and incorporate advantages not found in other prime movers.

- Simple and inexpensive variable speed and torque control with a flow control valve and/or pressure regulator.
- Intrinsically safe for explosion proof environments. The compact piston air motors are certified according to the European Explosion Directive ATEX II cat. 2 G&D T5.
- Air motors can be stalled indefinitely under load. They will not overheat or burn out.
- Long lifetime because of low friction and a minimum of parts that are exposed to wear.
- Controllable over a wide speed range.
- Instantly reversible, operated with a simple control valve.
- Resistant to warm, dirty and damp conditions.
- No shock start up which improves the life span of the equipment.



WHY CHOOSE A COMPACT PISTON AIR MOTOR?

Within the air motor family the compact piston air motor takes a special place, because this motor is often used in applications where other air motors can not be used.

- High torque at low speed of rotation. Therefore most of the times a gearbox is not necessary.
- Highest torque at start-up. The compact piston air motor does not have a variable starting torque. This always guarantees the rated starting torque.
- Possibility to connect up to three units in series if higher torque or power is required.
- Very low air consumption due the use of pistons, low internal friction and low internal air leakage.
- Low noise emission that fulfils the noise regulations without requiring ear protection.
- The compact piston air motors can be supplied directly coupled to a wide range of gearboxes such as planetary, helical, bevel helical and worm gears.
- Due the low speed of rotation the compact piston air motor is especially suitable for applications in which the air motor is constantly in stall.
- Compact construction made out of aluminium with steel shaft. Also available in a plastic housing with a stainless steel shaft.
- Integrated brake function. When both the inlet and outlet port are pressurised the motor functions as a brake with a torque of 50% of the starting torque.
- Able to run without lubrication. The compact piston air motors can operate with a minimum of lubrication. Complete oil-less operation is possible in certain applications. Consult Globe Airmotors BV or your local distributor for more information.

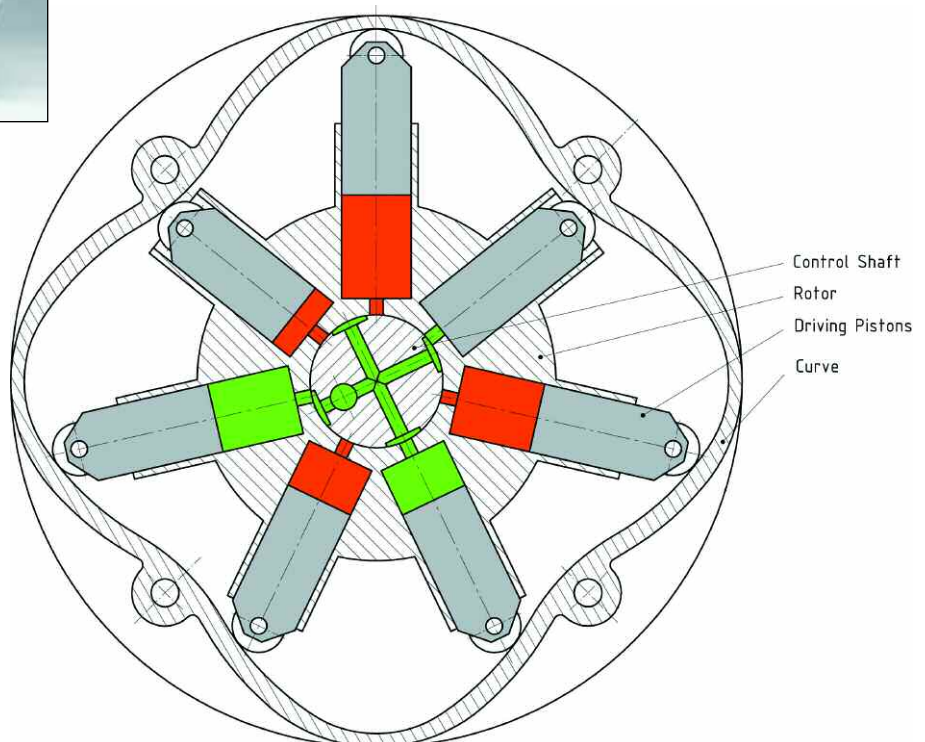

APPLICATIONS

Compact piston air motors are used in numerous of applications. Most suitable are light and medium duties at low speed operations. A combination of a GLOBE compact piston air motor with a large variety of gearboxes is possible when lower speed operations and/or higher torques are demanded for the application.



The most typical applications for compact piston air motors are:

- Mixing equipment
- Winding equipment
- Conveyor belts
- Hose Reels
- Turntables
- Packing machines
- Cap screwing machines

CONTROLLING AIR MOTORS

Speed regulation

Controlling the performance of an air motor is done by regulating the air supply. This is relatively cheap and simple. The methods to regulate the air supply are throttling and pressure regulation.

Throttling

The air flow is controlled by placing a flow control valve at the inlet port or the outlet port of the air motor. Throttling will reduce the maximum speed of the motor but will not affect the starting performance; the air pressure is unaffected at low flow conditions i.e. starting. Note the difference in the graph between throttling on the inlet port and outlet port.

Throttling methods

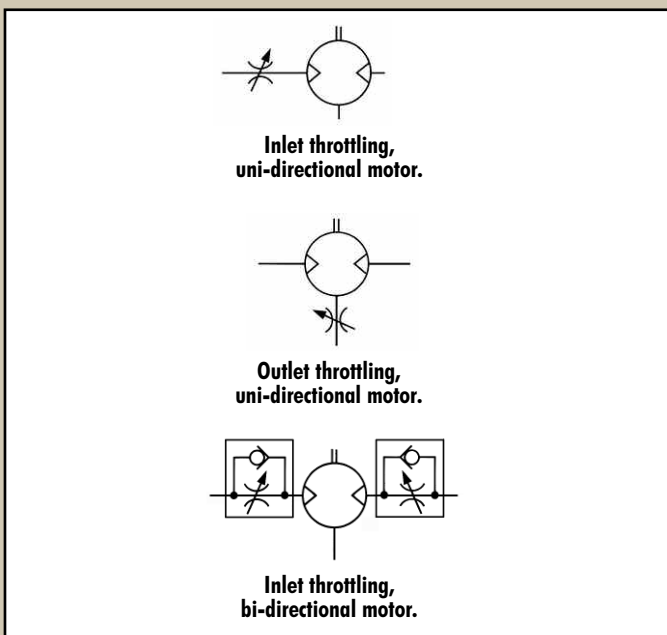

TORQUE

THROTTLING

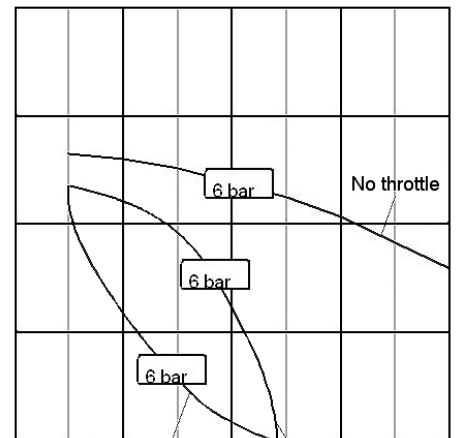

Inlet throttle Exhaust throttle SPEED

Pressure regulation

The speed and power can also be reduced by installing a pressure regulator on the incoming air supply. The pressure regulator reduces the air pressure to the motor. A pressure regulator is always fitted on the inlet port. By using a pressure regulator the torque on the output shaft will be affected, starting torque is best controlled with this method.

Pressure regulating method

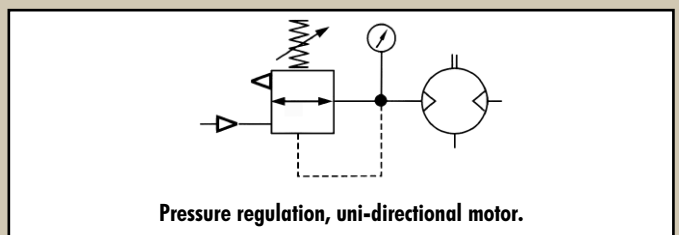

When both the speed and the torque are to be controlled the best configuration is to use a pressure regulator in the air line to the motor and a flow control valve on the outlet port. This way every point in the torque-speed graph can be set accurately.

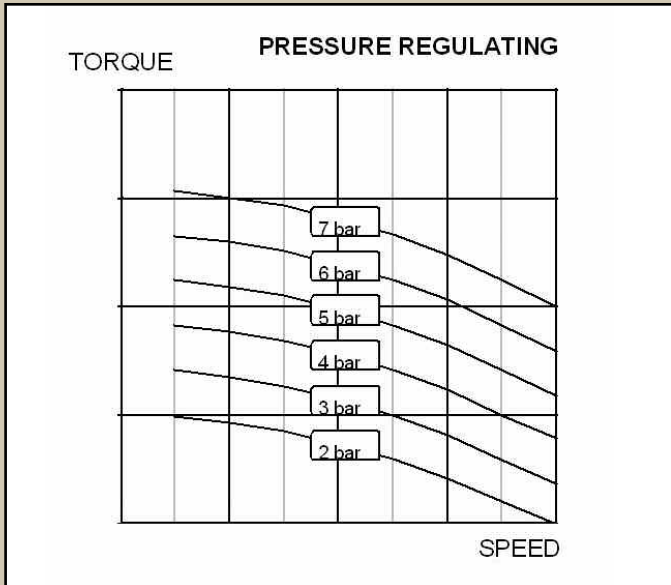

Directions of rotation

The GLOBE piston air motors can be used both as a uni-directional and as a bi-directional air motor. When the air motor is used in a non-reversible application, it is sufficient to use a 2/2 or a 3/2 valve. For the reversible motor you can use either a 5/3 or two 3/2 valve to gain directional control.

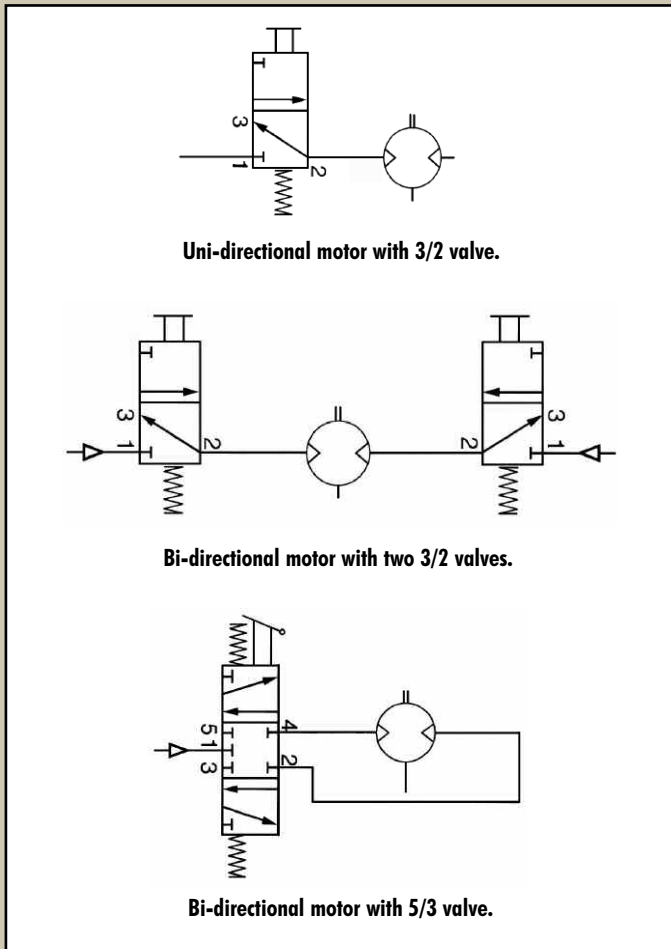

Air supply

Air quality

To insure optimal working conditions for the GLOBE piston air motors, the air supply must be dry, filtered and lubricated. A 5 micron filter or better is recommended. The GLOBE piston air motors should be lubricated sufficiently. Oilless operations are possible in certain applications.

Air line restrictions

Air line restrictions on the inlet side of the motor will result in performance loss. Therefore it is important to make sure that the desired air pressure is available at the motor during operation. The pressure reading at the compressor or pressure regulator may be different then the pressure available at the motor. Performance loss can also occur by an exhaust restriction generating back pressure on the outlet side of the motor. An insufficiently sized silencer, valve or coupling is usually the cause.

GEARED VANE AIR MOTORS

Although air motors can be adjusted over a wide range of speed and torque, the output characteristics are not always suitable for the application. To achieve the required output speed and torque a gearbox can be coupled directly to the air motor.

GLOBE Airmotors BV has a wide range of gear units such as planetary, helical, bevel helical and worm gears in their program. Consult Globe Airmotors BV or your local distributor for more detailed information.



DIMENSIONS RM004

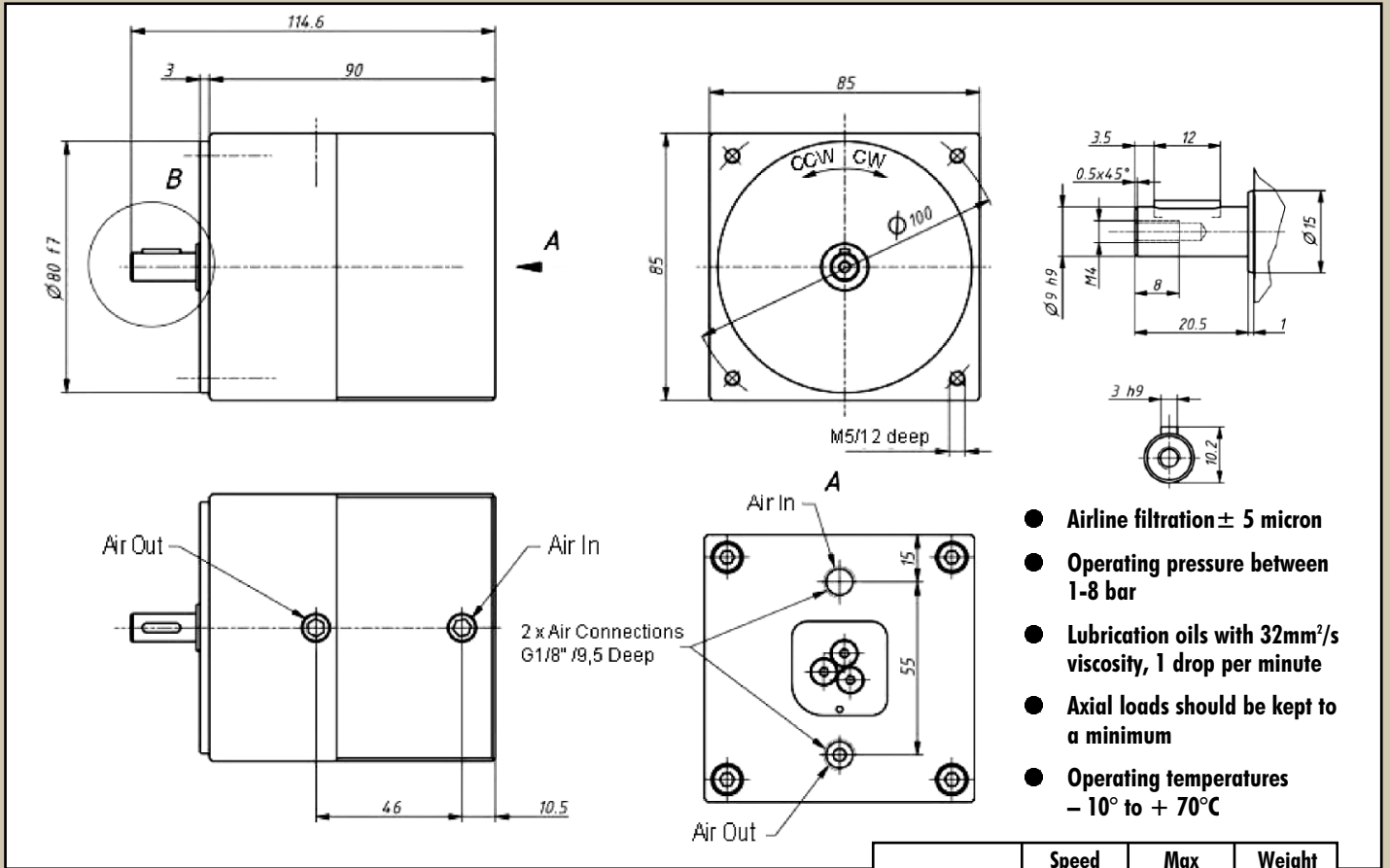

Uni-directional - to be ordered in Counter Clockwise (CCW) or Clockwise (CW) direction

At 8 bar	Speed	Max Power	Weight
	(RPM)	(W)	(kg)
RM004	60-800	110	2,1

PERFORMANCE RM004

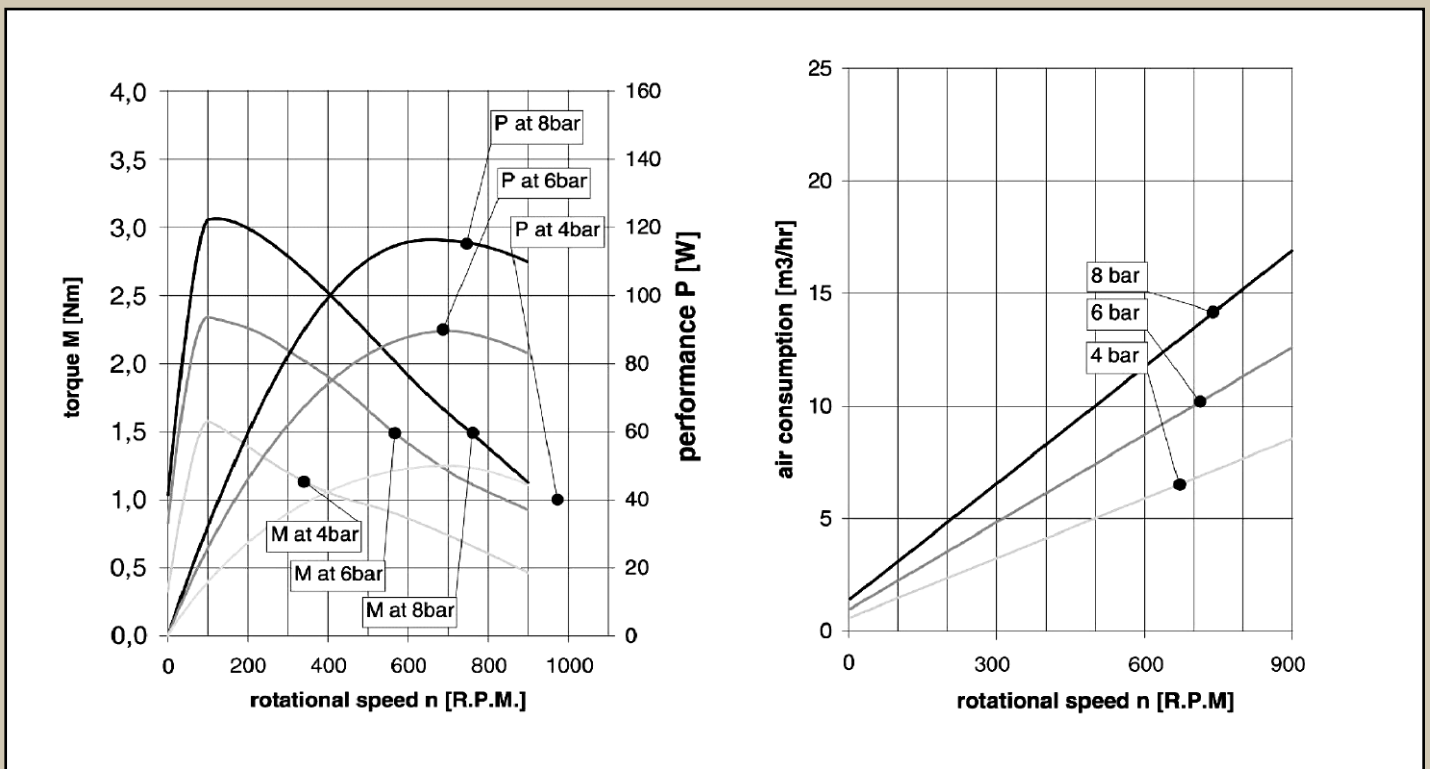

DIMENSIONS RM015-1-A-0

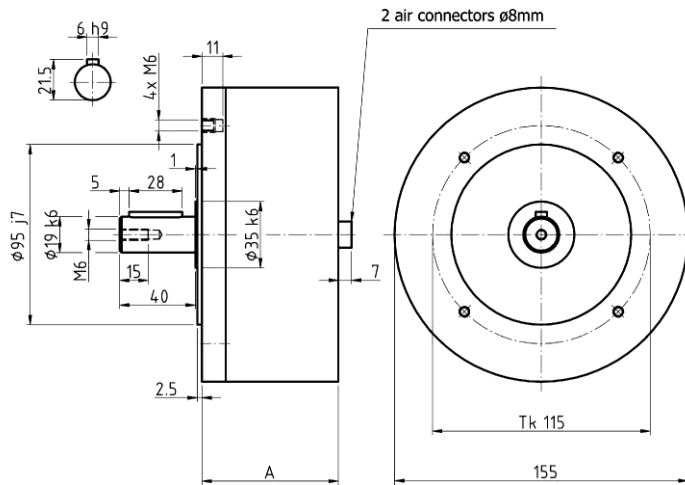

- Airline filtration ± 5 micron
- Operating pressure between 1-8 bar
- Lubrication oils with $32 \text{ mm}^2/\text{s}$ viscosity, 1 drop per minute
- Axial loads should be kept to a minimum
- Operating temperatures – 10° to $+ 70^\circ\text{C}$

At 8 bar	A	Speed	Max Power	Starting Torque	Weight
	mm	(RPM)	(W)	(Nm)	(kg)
RM015-1-A-0	72	10-350	160	15	4,0
RM015-2-A-0	102	10-350	320	30	5,5

PERFORMANCE RM015-1-A-0

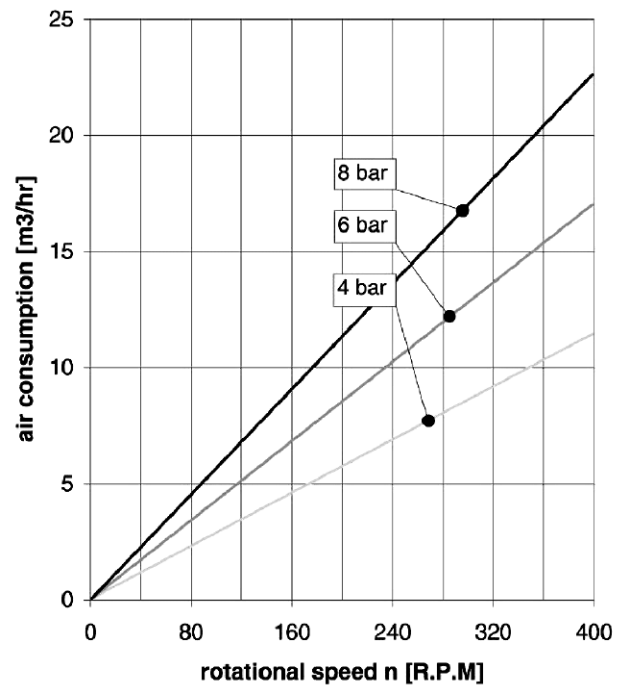
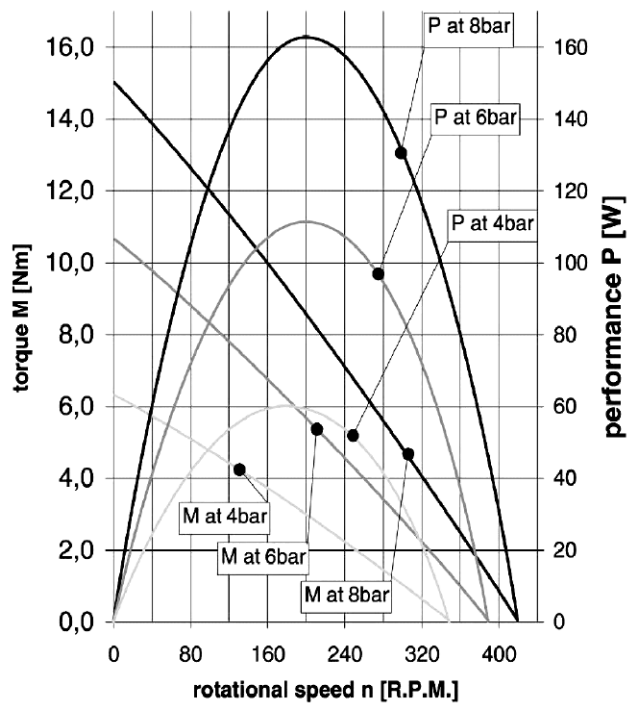

DIMENSIONS RM015-1-P-0

(Plastic Housing, Stainless Steel Shaft, Water resistant, Lubrication Free), no ATEX

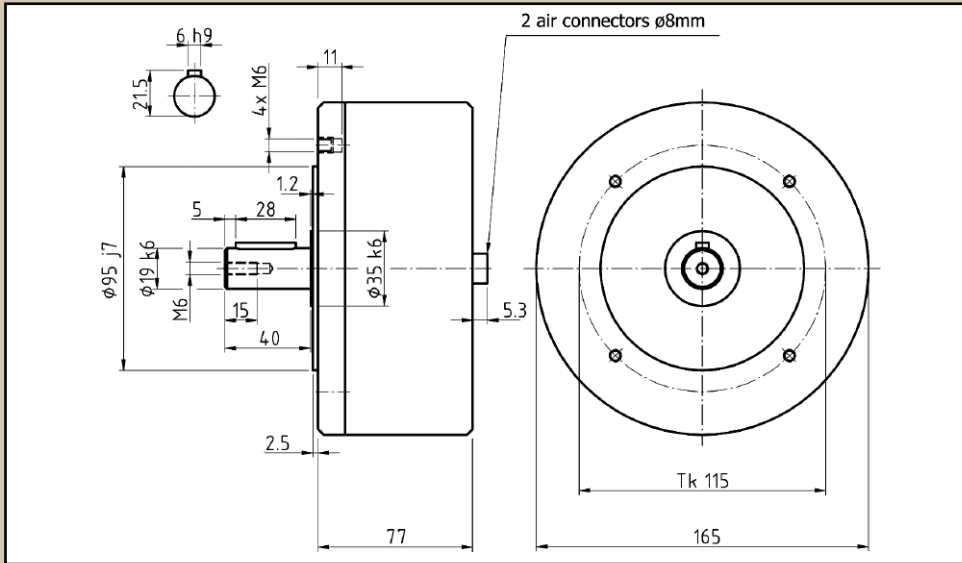

- Airline filtration ± 5 micron
- Operating pressure between 1-8 bar
- Lubrication oils with $32 \text{ mm}^2/\text{s}$ viscosity, 1 drop per minute
- Axial loads should be kept to a minimum
- Operating temperatures -10° to $+70^\circ \text{C}$

At 8 bar	Speed	Max Power	Weight
	(RPM)	(W)	(kg)
RM015-1-P-0	10-350	145	3.6

PERFORMANCE RM015-1-P-0

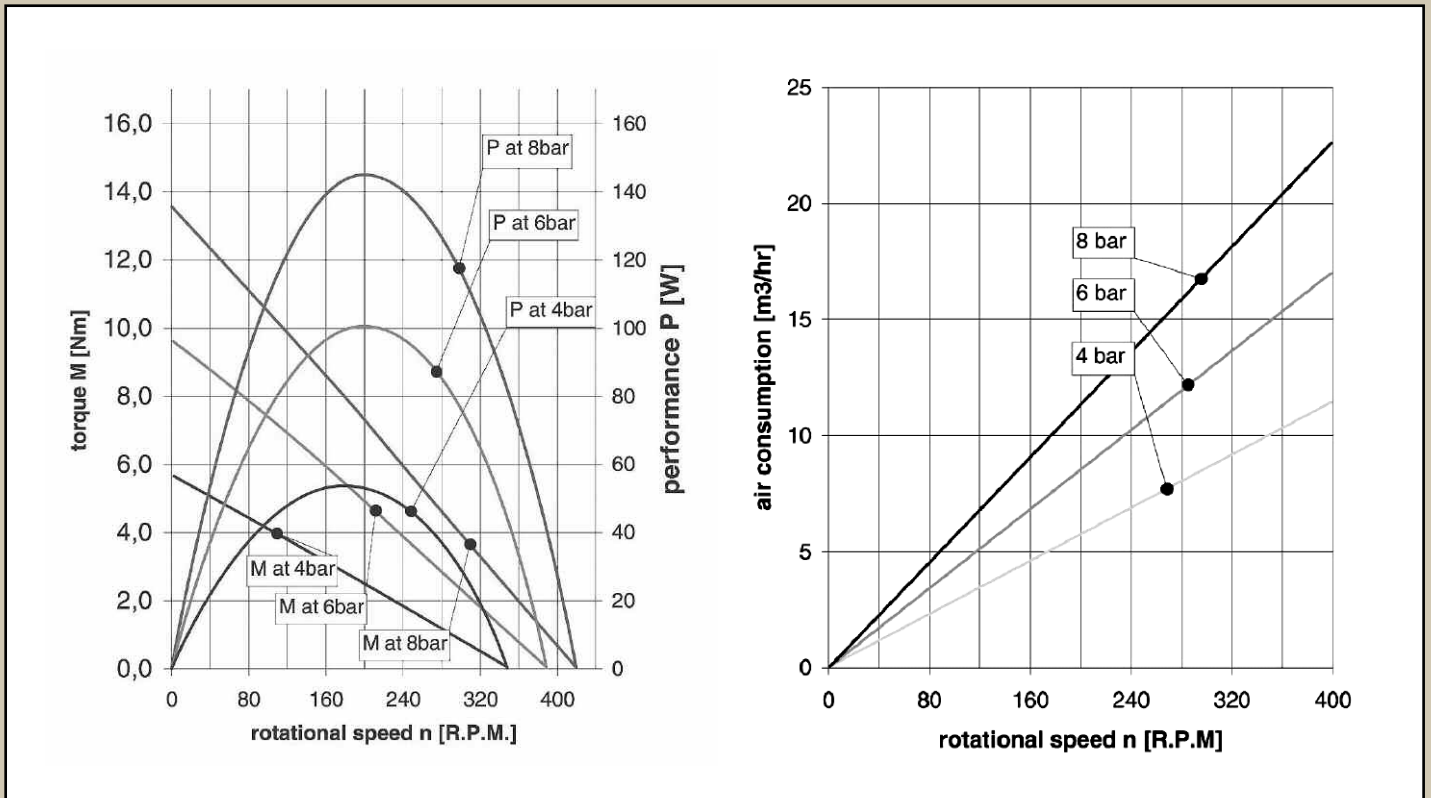

RM015-1-P-0, Plastic Housing,
Stainless Steel Shaft,
Waterresistant, Lubricant Free



DIMENSIONS RM025-1-A-0

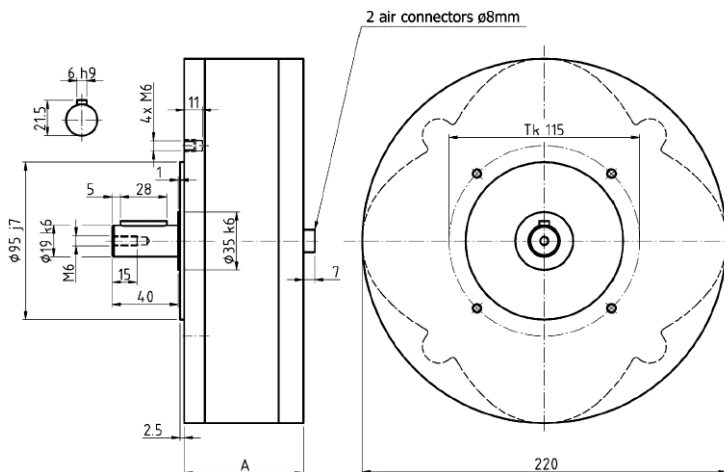

- Airline filtration ± 5 micron
- Operating pressure between 1-8 bar
- Lubrication oils with $32\text{mm}^2/\text{s}$ viscosity, 1 drop per minute
- Axial loads should be kept to a minimum
- Operating temperatures -10° to $+70^\circ\text{C}$

At 8 bar	A	Speed	Max Power	Starting Torque	Weight
	mm	(RPM)	(W)	(Nm)	(kg)
RM025-1-A-0	72	10-250	180	25	5,8
RM025-2-A-0	102	10-250	360	50	7,5

PERFORMANCE RM025-1-A-0

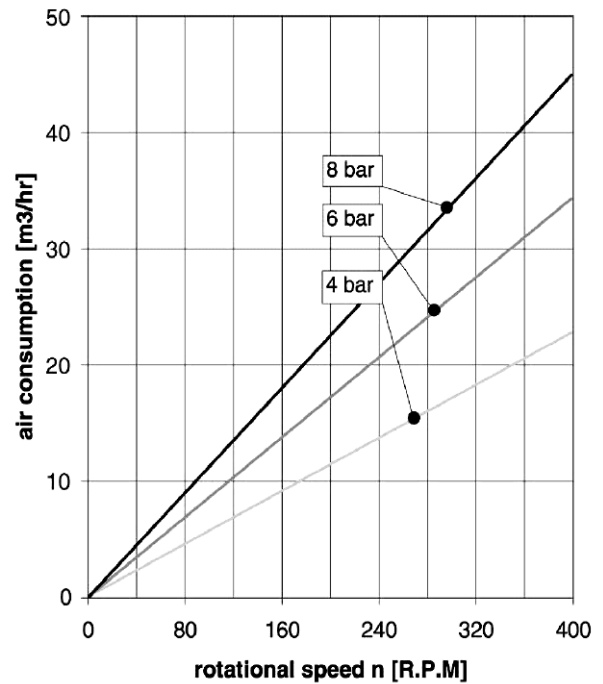
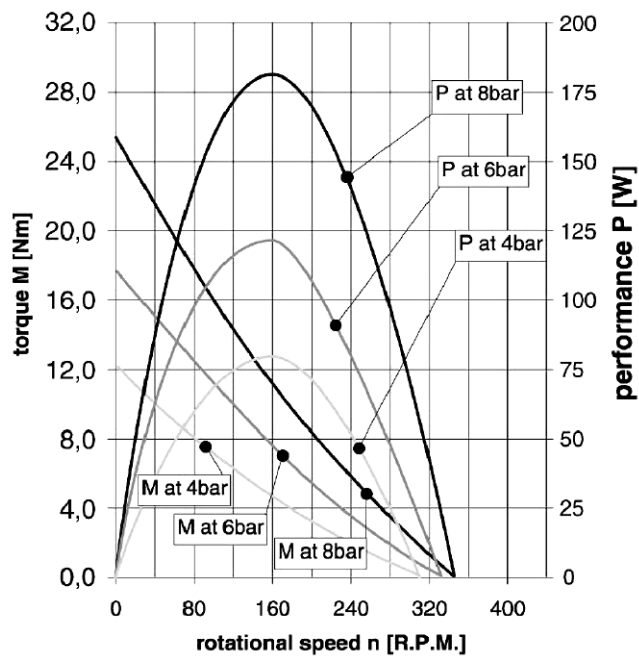

SPECIAL EXECUTIONS - DOUBLE STAGE AIR MOTORS

PERFORMANCE RM015-2-A-0

- Airline filtration ± 5 micron
- Operating pressure between 1-8 bar
- Lubrication oils with $32\text{mm}^2/\text{s}$ viscosity, 1 drop per minute
- Axial loads should be kept to a minimum
- Operating temperatures $- 10^\circ$ to $+ 70^\circ\text{C}$

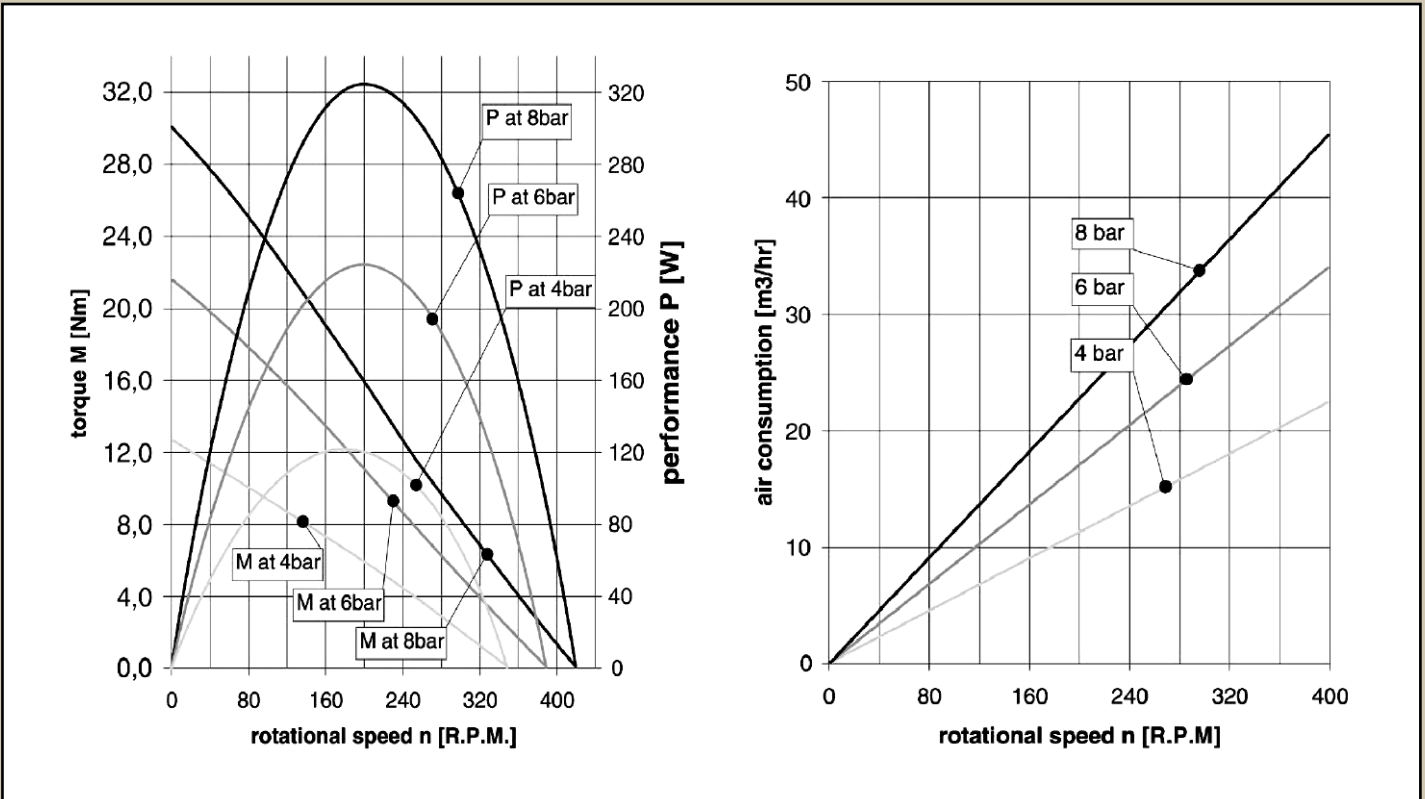

PERFORMANCE RM025-2-A-0

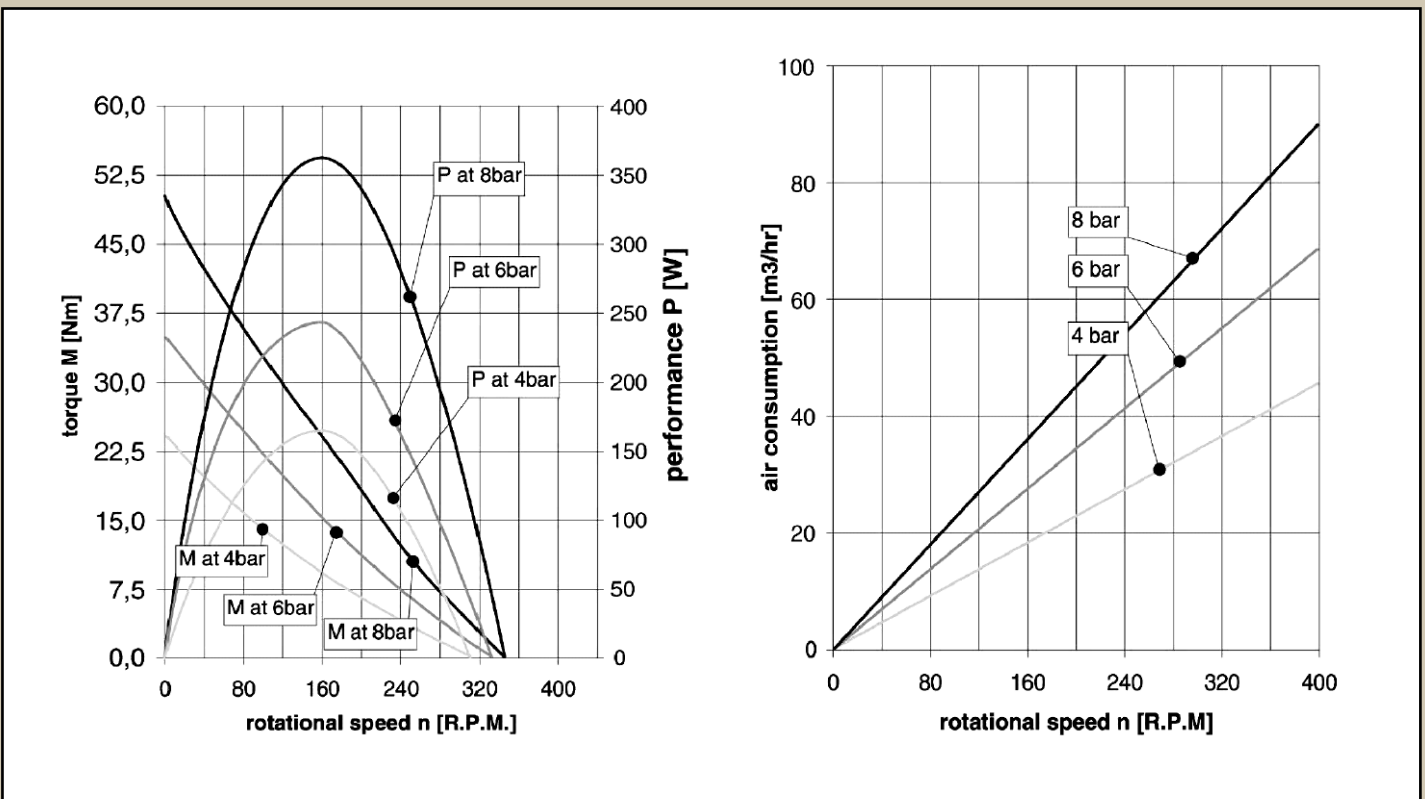

LOAD DIAGRAM FOR RM015-1-A-0, RM015-2-A-0, RM015-1-P-0, RM025-1-A-0, RM025-2-A-0

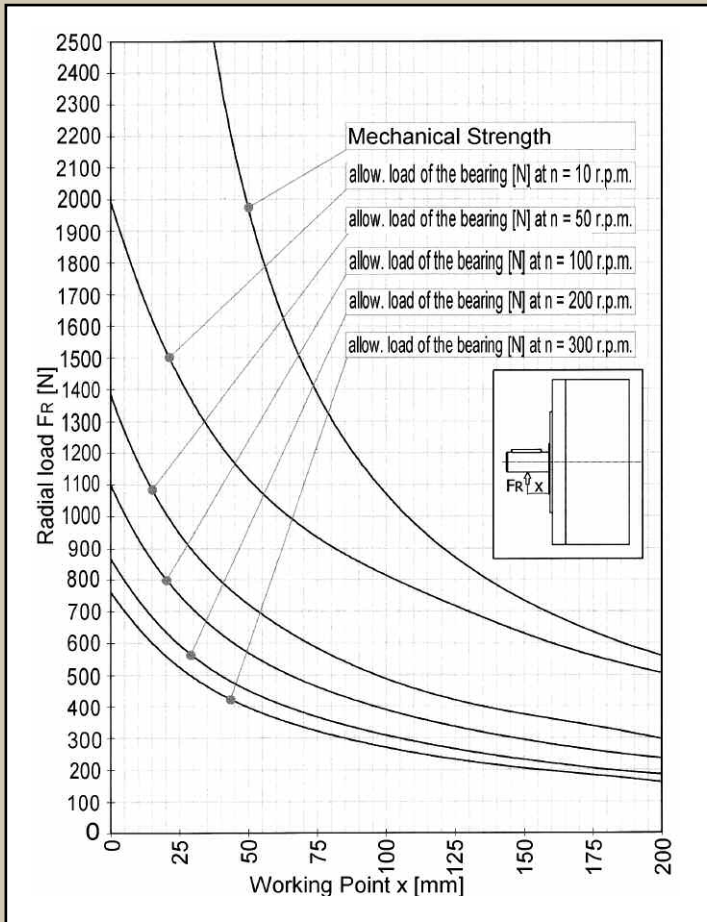

MODEL ORDERING CODE

RM004 – CW/CCW
 RM015 – X – X – X
 RM025 – X – X – X

CW = clockwise
 CCW = counter clockwise
 (looking on the shaft)

0 = no gear
 2,5 = reduction 2,5:1

A = Aluminium
 P = Plastic housing and
 stainless steel shaft
 (waterresistant)

1 = 1 stage
 2 = 2 stages

Ordering example

You order the RM015 1P0. We deliver the compact piston air motor type RM015 with 1 stage, a plastic housing and stainless steel shaft (waterresistant) and no gear.



Globe Airmotors Program



Vane Air Motor

Reversible, available in flange, foot, or face execution.
Power from 0,44 to 9,5 kW.



Compact Air Motor

Reversible, compact, available with a wide range of incorporated reduction units. Power from 180 to 1000 W.



Planetary Geared Vane Air Motor

Reversible and a compact solution. Available with gear ratios from 3:1 to 1000:1. Power from 0,44 to 5,4 kW.



Vane Air Motor with Gearbox

Available with planetary, coaxial, or worm gearboxes. Also possible with pneumatic brake.



Compact Piston Air Motor

High torque at low speed of rotation, very low air consumption and low noise level.
Power from 110 to 460 W.



Radial Piston Air Motor

Available with proportional hand or remotely controlled valve, pneumatic brake and all types of gearboxes.
Power from 0,8 to 23 kW.

DISTRIBUTOR



GLOBE AIRMOTORS B.V.

Eikenlaan 261e
NL-2404 BP Alphen a/d Rijn
Tel: (+31)-(0)172-426608
Fax: (+31)-(0)172-426607
Website: <http://www.globe-benelux.nl>
E-mail: info@globe-benelux.nl