

R Series EExia Aluminum

3/2, 5/2, 5/3 Function Solenoid Valve EExia IIC T6

Intrinsically Safe Aluminum Enclosure, CNOMO Interface



ABR2AG-M

[FEATURES]

- Integral terminal box with coil housing.
- Stainless steel 316 spool for all models.
- Interchangeable CNOMO interface for various coil options available.
- Single coil spring return function or double coil stay put function.
- Low power consumption.
- Operates with a wide range of barriers and galvanic isolators.
- Inner epoxy molded coil.

[INTRODUCTION]

3 port 2 position, 5 port 2 position and 5 port 3 position pilot operation solenoid valve. Suitable for Zone 0, 1 and 2, manufactured in accordance with the requirements of the European harmonized standards EN50014 and EN50020. EExia IIC T6.

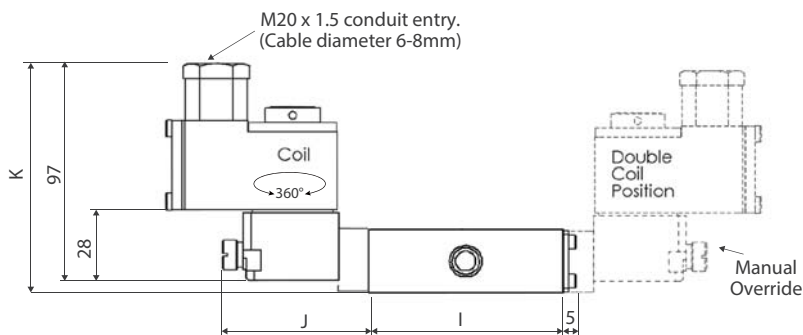
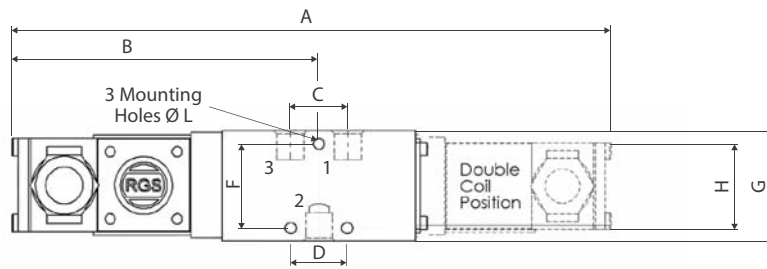
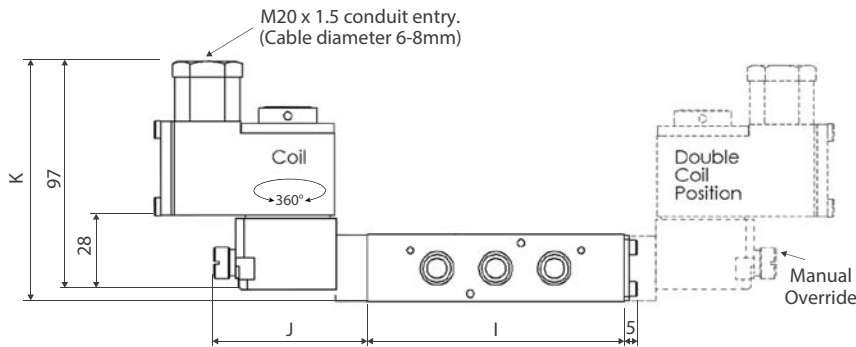
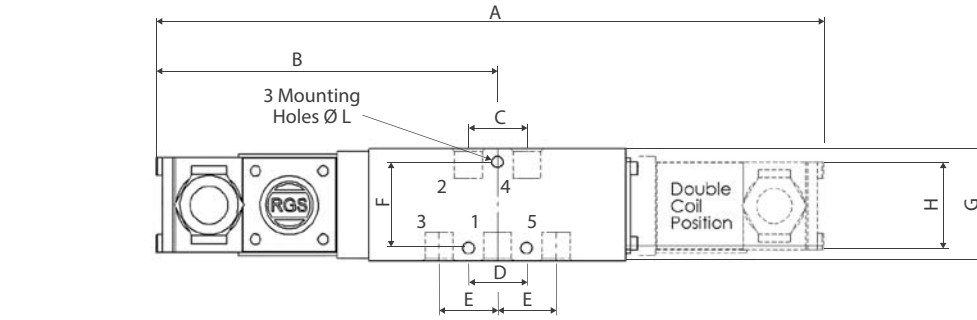
[DIMENSION]

M20 male to 1/2" NPT female thread adaptor (C)

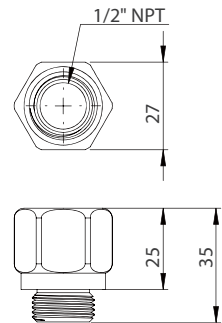

BODY TYPE		DIMENSIONS (mm)											
		A	B	C	D	E	F	G	H	I	J	K	L
5 Ports 2 Position & 3 Position	1/4 NPT	293	146.50	22	21.80	22	32.20	42.20	36	96.50	50	90.50	4.3
	3/8 NPT	293	146.50	22	21.80	22	32.20	42.20	36	96.50	50	90.50	4.3
	1/2 NPT	335	167.50	32	30.20	31.75	47.6	63.20	36	138	51	93.50	8.7
3 Ports 2 Position & 3 Position	3/4 NPT	335	167.50	32	30.20	31.75	47.6	63.20	36	138	51	93.50	8.7
	1/4 NPT	270	135	22.20	21.80	-	32.20	42.20	36	74	50	90.50	4.3
	3/8 NPT	270	135	22.20	21.80	-	32.20	42.20	36	74	50	90.50	4.3
3 Position	1/2 NPT	302	151.50	31.75	30.20	-	47.6	63.20	36	106.45	51	93.50	8.7
	3/4 NPT	302	151.50	31.75	30.20	-	47.6	63.20	36	106.45	51	93.50	8.7

[VALVE]

MATERIAL SPECIFICATION	STANDARD
Body	Aluminum and Stainless Steel
Spool	Stainless Steel
Seals	H-NBR
Spring	Stainless Steel

VALVE SPECIFICATION	STANDARD
Port Connection Size	1/4" - 3/4" NPT
Working Pressure Internal Pilot Version	2 to 8 bar
Cv Factor	2.0 ~ 4.8
Maximum Ambient Temperature	+65°C
Minimum Working Temperature	-10°C

[COIL]

MATERIAL SPECIFICATION	STANDARD
Coil Case	Zinc Alloy Epoxy Powderder Coated
Armature	Magnetic Solenoid Quality Stainless Steel
Springs	Stainless Steel
Seals and Seat	Viton
Coil Former	30% Glass Filled PBT
Magnetic	Class H Coated Copper

SOLENOID	STANDARD
Type	DC Solenoid Coil
Voltage Standard	24
Voltage Tolerance	±10%
Ambient Temperature	-10 to +65°C
Duty Cycle	100%
Degree of Protection	IP66
Connection	PG.9 Cable Gland / M20 Tread
Power Consumption	0.4 Watts with Barrier
Current Consumption	33 mA at 12 Volts with barrier
Resistance	370 Ohms
Inductance (Apparent)	Zero
Capacitance	Zero

POWER SUPPLY	STANDARD
U, normal, allowable	24 VDC / 31 VDC
I, normal, allowable	** / 0.67 A
W, normal, allowable	** / 2.98 W

 ** depending on safty barrier, and see **NOTE3** for more info.

[PRODUCT CODE]

COIL

VOLTAGE

SERIES CODE

PORT

VALVE MATERIAL

FUNCTION

OPTION

COIL

A AV636A00 RGS AV636A00 EExia Operator with Aluminum Enclosure.

VOLTAGE

B 24V DC (intrinsically safe)

PORT

2 1/4" CV2.0

3 3/8" CV2.0

4 1/2" CV4.5

6 3/4" CV4.8

VALVE MATERIAL

S Stainless Steel

A Aluminum

FUNCTION

A 5/2 Single Acting



G 3/2 Single Acting, Normally Closed



B 5/2 Double Acting



H 3/2 Single Acting, Normally Open



C 5/3 3 Position Block Center



I 3/2 Double Acting



D 5/3 3 Position Exhaust Center



J 3/3 3 Position Block Center



E 5/3 3 Position Pressure Center



OPTION

C 1/2" NPT Electric Conduit

X Customized (Additional Code is required)

M Manual Override

P External Pilot Air Connection

H High Temperature FKM Seal

[INTRINSIC SAFETY]

Intrinsic safety is the safest form of protection for electrical equipment operating in potentially hazardous atmospheres. Intrinsic safety (IS) is based on the principle of restricting the electrical energy available in hazardous area circuits such that any sparks or hot surfaces that may occur as a result of electrical faults are too weak to cause ignition.

An intrinsically safe system consists of a certified IS interface which passes signals to and from the process (hazardous area) but limits the energy (that is voltage and current) that can reach the hazardous area under fault conditions.

The interface is usually mounted in the safe area and can be either a shunt diode safety barrier or a galvanic isolator.

In the hazardous area 'simple' or 'non-energy storing devices' (switches thermocouples & LED's) can be used without certification but 'Energy-storing' equipment such as solenoid valves must be designed so as to prevent this energy escaping and of necessity need to be of sufficiently low power to operate within the constraints of the IS signal.

[HAZARDOUS AREA SOLENOID VALVE]

The RGS EP000/ia solenoid coil is approved for this duty and is certified safe for all classified areas of hazard and gasses when installed in accordance with an approved system. The coil is protected by diodes which suppresses the inductance, effectively to zero, and there is no capacitive characteristics in the coil either.

The coil assembly, which is encapsulated, forms a compact solenoid actuator to interchange with the standard (non-hazardous duty) coil fitted to the 3 and 4 way spool valves.

The IS coil because of its low wattage requires that the spring load and travel of the armature be closely controlled and for this reason each solenoid has an inbuilt adjustable jet which is factory set so as to control the operating characteristics of the coil. Where the IS solenoid actuator is fitted to the spool valve, the jet in the end cap which is required for the normal coil, is removed.

[SOLENOID VALVE CONTROL SYSTEM]

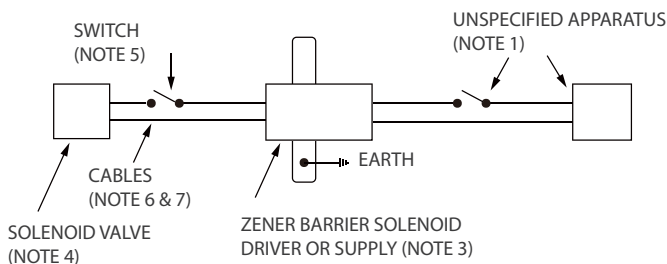
TABLE 1 (NOTE 7)

GROUP	CAPACITANCE (μF)	INDUCTANCE (mH)	L/R RATIO (μH/ohm)
IIC	0.13	1.32	40
IIB	0.39	3.96	120
IIA	1.04	10.56	320

NOTE 1

This apparatus is unspecified except that it must not contain under normal or abnormal conditions a source of potential with respect to earth in excess of 250V R.M.S. or 250V DC.

NOTE 2

The electrical circuit in the Hazardous area must be capable of withstanding an AC test voltage of 500V R.M.S. to earth of frame of the apparatus for one minute.

NOTE 3

Any single channel or single channel of a multiple channel shunt zener diode safety barrier, solenoid driver or supply certified by any EU notified certification body to [EExia] IIC, Whose output voltage (U_z , $U_{max. : out}$ OR U_o) does not exceed 28V and whose output current ($I_{max. : out}$ OR I_o) is limited by resistance 'R' such that the output voltage (U_z , $U_{max. : out}$ OR U_o) does not exceed 25.5V and whose output current ($I_{max. : out}$ OR I_o) is limited by resistance 'R' such that the output voltage divided by 'R' does not exceed 147mA.

NOTE 4

R.G.S. solenoid valve covered by Certificate of Conformity BAS. No. EX822147 to category EExia IIC T6.

NOTE 5

Switch must be selected and installed to meet the requirements of clauses 4.1 and 5 of EN50 020.

NOTE 6

The cable maybe twin pair, or a pair contained in a type A, or type B multicore cable (as defined in class 5.3 of EN50 039), provide that the peak voltage of any circuit contained within the multicore does not exceed 60 volts.

NOTE 7

The capacitance and inductance to resistance ratio of the hazardous area cables must not exceed the values shown in table 1.

[METHODS OF PROTECTION]

The generic term for all methods of protection of electrical equipment used in Europe is 'explosion proof'. American practice is to use this term for flameproof equipment. The table lists the more usual methods of protection.

TECHNIQUES	
Oil Immersion	o
Pressurisation	p
Powder Filling	q
Flameproof Enclosure	d
Increased Safety	e
Intrinsically Safe	ia
Intrinsically Safe	ib
Non-incendive	N
Encapsulation	m
Special Protection	s

[SOLENOIDS VALVES IN HAZARDOUS AREAS]

Not all of these methods are applicable to solenoid protection, the more commonly used are listed below.

1. **Flameproof** This form of protection entails enclosing the coils in a robust enclosure which will contain an internal explosion should it occur and prevent its transmission to the surrounding atmosphere.
2. **N-Type Protection (Non-incendive)** Generally applied to non-sparking electrical components such as a solenoid coil which will not get abnormally hot even if the armature is locked out.
3. **Encapsulation** This involves enclosing the coil and any associated electrical components in a compound so as to prevent the ignition of a surrounding explosive atmosphere.
4. **Intrinsically Safe** Intrinsic safety is a technique that achieves safety by limiting the electrical-spark energy (and surface temperature) that can arise in hazardous area circuits to levels that are insufficient to ignite an explosive atmosphere.

An intrinsically safe system consists of a certified Intrinsically safe interface which passes signals to and from the process (hazardous area) but limits the energy (that is voltage and current) that can reach the hazardous area under fault conditions.

The interface is usually mounted in the safe area and can be either a shunt diode safety barrier or a galvanic isolator.

In the hazardous area 'simple' or 'non-energy storing devices' (switches, thermocouples & LED's) can be used without certification but 'Energy-storing' equipment such as solenoid valves must be designed so as to prevent this energy escaping and of necessity need to be of sufficiently low power to operate within the constraints of the IS signal.
5. **Special Protection** Offers combination of one or more methods of protection and in the case of solenoids these are usually 'e' and 'm', where the coil is encapsulated, has over temperature protection and the terminals are approved under the increased safety requirement.